



**Semitrailer
TIGER TDC 368 – C53
“Classic” version
Rear Tipper**



Semitrailer TIGER 53mc – Rear Tipper with two cylinders

CHASSIS

- Gervasi chassis, made by hi-performance steel
- N° of axles: 3 simple axles
- Suspension: pneumatic suspension
- Brakes: disc brakes with ABS
- Tyres: nr. 7 tyres 385/65R22,5 on steel rims (*optional aluminium*)
- Front steering axle and front lifting axle

BODY

- External dimensions 12.250 x 2.530 x 1.900mm (Volume 53 m³)
- HARDOX bottom – thickness: 50/10 (5 mm)
- HARDOX sides – thickness: 40/10 (4 mm) with welded reinforcements
- Rear doors with manual opening and pneumatic safety device

LIFTING SYSTEM

- Body lifting by means of two side – mounted cylinders
- Patented flow distributor valve
- Rear tipping hinges on cushions
- Lifting control in driver’s cab
- Lifting angle 40°

STANDARDS

- Rear bumper
- Front ladder
- Toolbox
- Half mudguard, front and rear, on each side
- Parking wedges with relative supports
- Side protections. – LED Side lights. – Rear reflecting panels. – Reflecting stripes

WEIGHTS

<i>Model</i>		TIGER C53
Dead weight	[kg.]	*11.400
Total weight	[kg.]	36.800

* Dead vehicle with 6 tyres and 6 aluminum rims.

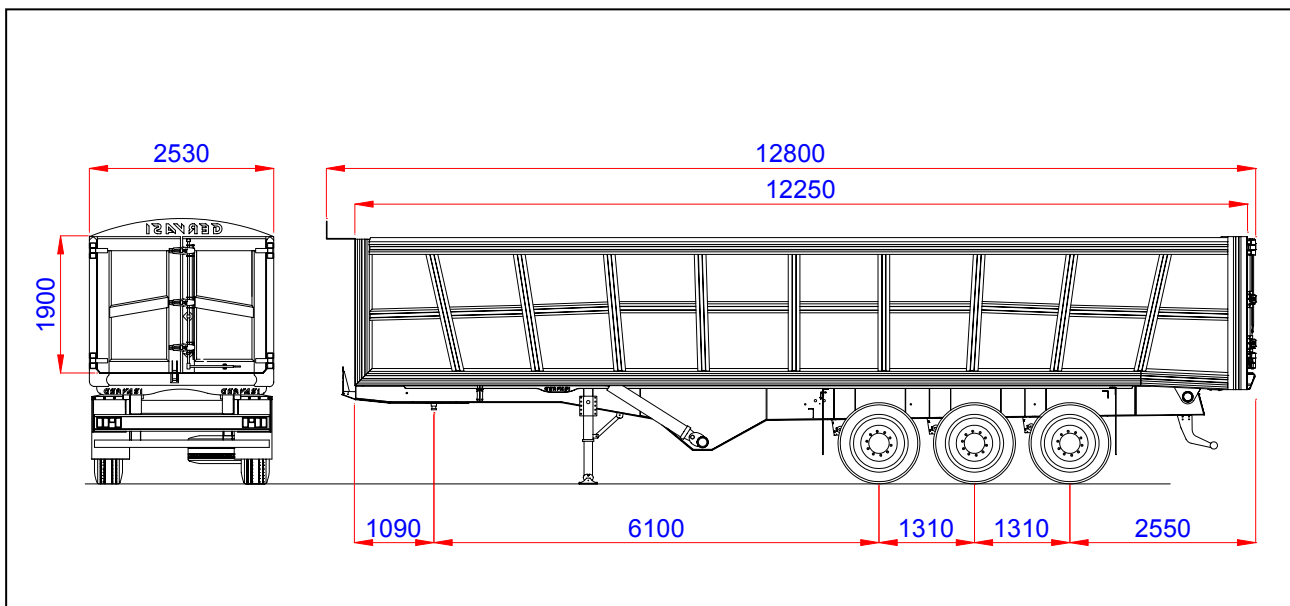

The dimensions and weights stated herein are indicative and not binding, and may be changed without warning as a function of production needs.



**Semitrailer
TIGER TDC 368 – C59
“Classic” version
Rear Tipper**



Semitrailer TIGER 59mc – Rear Tipper with two cylinders

CHASSIS

- Gervasi chassis, made by hi-performance steel
- N° of axles: 3 simple axles
- Suspension: pneumatic suspension
- Brakes: disc brakes with ABS
- Tyres: nr. 7 tyres 385/65R22,5 on steel rims (*optional aluminium*)
- Front steering axle and front lifting axle

BODY

- External dimensions 12.250 x 2.530 x 2.100mm (Volume 59 m³)
- HARDOX bottom – thickness: 50/10 (5 mm)
- HARDOX sides – thickness: 40/10 (4 mm) with welded reinforcements
- Rear doors with manual opening and pneumatic safety device

LIFTING SYSTEM

- Body lifting by means of two side – mounted cylinders
- Patented flow distributor valve
- Rear tipping hinges on cushions
- Lifting control in driver’s cab
- Lifting angle 40°

STANDARDS

- Rear bumper
- Front ladder
- Toolbox
- Half mudguard, front and rear, on each side
- Parking wedges with relative supports
- Side protections. – LED Side lights. – Rear reflecting panels. – Reflecting stripes

WEIGHTS

<i>Model</i>		TIGER C59
Dead weight	[kg.]	*11.600
Total weight	[kg.]	36.800

* Dead vehicle with 6 tyres and 6 aluminum rims.

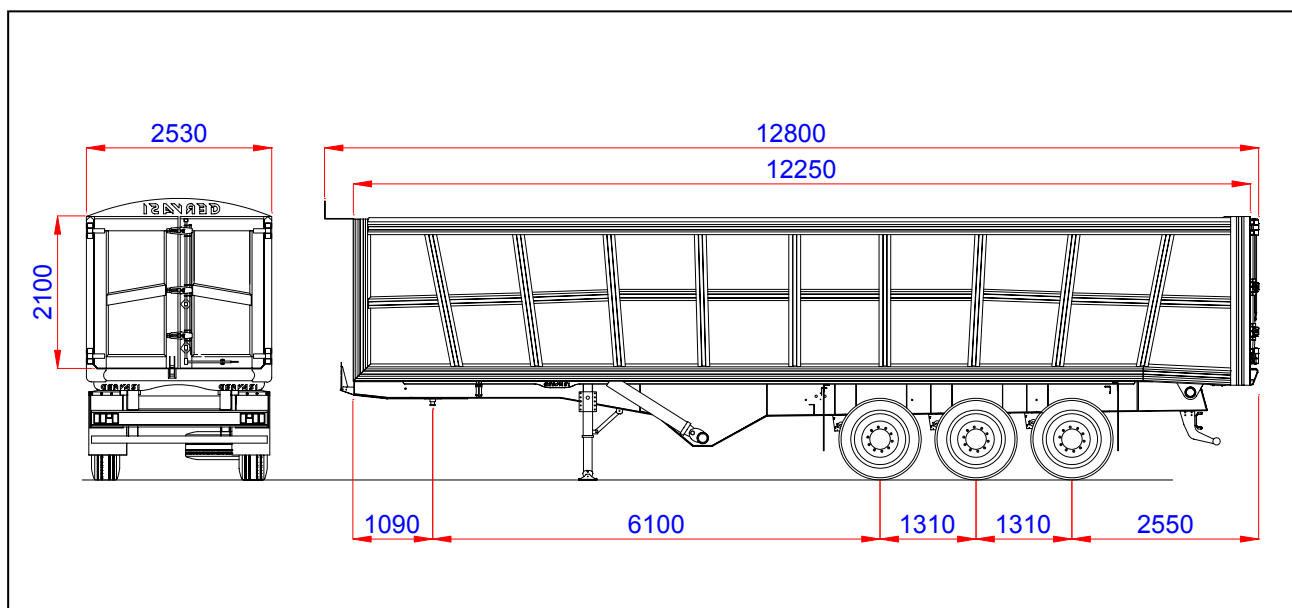

The dimensions and weights stated herein are indicative and not binding, and may be changed without warning as a function of production needs.