

## Semitrailer ARKTOS 55mc – Rear Tipper

### CHASSIS

- chassis made by hi-performance steel
- N° of axles: 3
- Suspension: mechanical suspension (*optional pneumatic suspension*)
- Brakes: drum brakes with ABS (*optional disc brakes*)
- Tyres: nr. 11 tyres 315/80R22,5 on steel rims
- Front steering axle and front lifting axle

### BODY

- External dimensions 11.000 x 2.540 x 2.200mm (Volume 55 m<sup>3</sup>)
- HARDOX bottom – thickness: 60/10 (6 mm)
- HARDOX sides – thickness: 40/10 (4 mm) with welded reinforcements
- Rear doors with manual opening and pneumatic safety device

### LIFTING SYSTEM

- Body lifting by means of one central – mounted cylinder
- Rear tipping hinges on cushions
- Lifting control in driver's cab
- Lifting angle 45°

### STANDARDS:

- Rear bumper
- Front ladder
- Toolbox
- Half mudguard, front and rear, on each side
- Parking wedges with relative supports
- Side protections. – LED Side lights. – Rear reflecting panels. – Reflecting stripes

### WEIGHTS

Model		ARKTOS 50
Dead weight	[kg.]	*12.100
Total weight	[kg.]	36.800

\* Dead vehicle with 10 tyres and 10 rims.

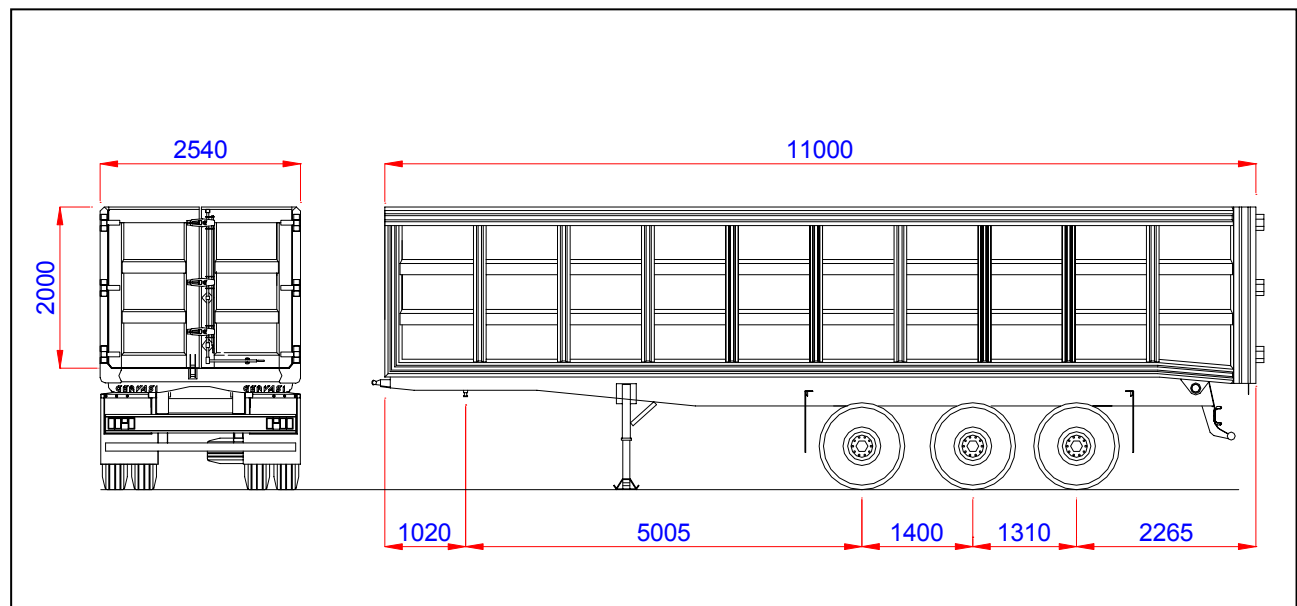

The dimensions and weights stated herein are indicative and not binding, and may be changed without warning as a function of production needs.