

“SEMIROCCIA”

Tail gate thickness	Front panel thickness	Body inside dimensions
5 mm	5 mm	5700 x 2300 x 1450 mm

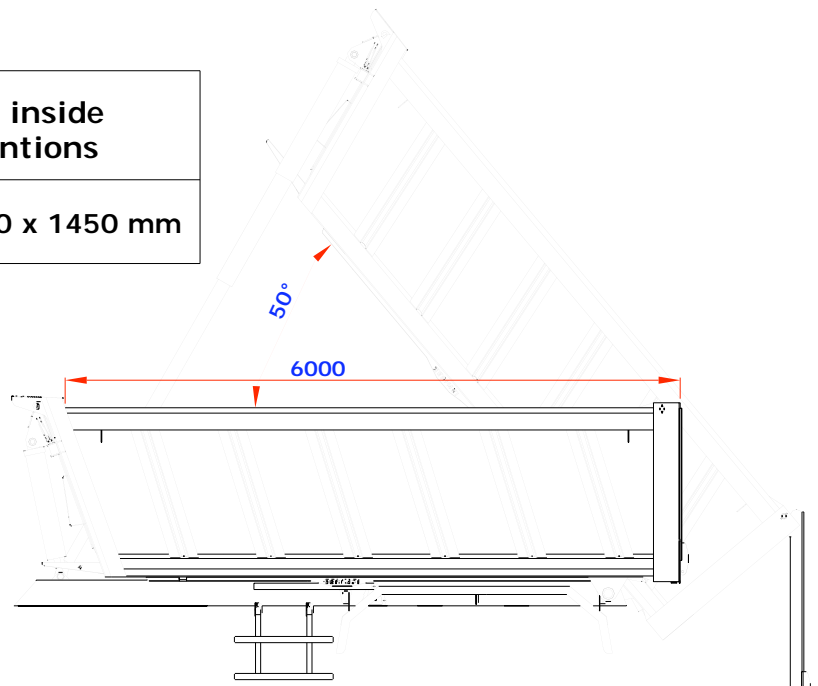
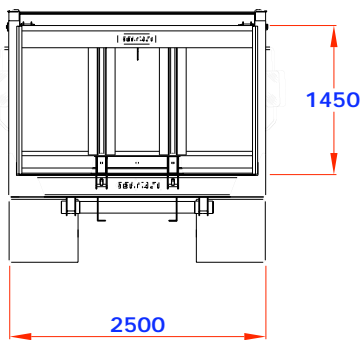

Body Volume	Tipping structure Weight	Floor	Side Walls	Body lifting angle
18 mc.	4800 kg.	HB 450 steel Thickness 8 mm	HB 450 steel Thickness 5 mm	50°

The dimensions and weights are indicative. They can be changed without warning for manufacturing needs. F.I.I. Gervasi S.p.A.

EMPLOY

- Bulk material (sand, gravel, asphalt,).

TIPPER BODY

- Fixed side walls with welded reinforcements.
- Front board with cab protecting lid.
- Top hinged tail gate with automatic release.
- Tipping control by means of front telescopic hydraulic cylinder.
- Activation by means of pneumatic control from the cab.
- Safety device at rear, bolted to the vehicle frame, complete with rubber body support when lifting.
- Painting:
 - Sandblasting by means of computerised system;
 - Application of polyurethane primer and finishing enamel.
- Painting colour: subframe in RAL 7021, body in customer colour.

STANDARD EQUIPMENTS

- Rear steel mudguards.
- Stainless steel tool box with lock (210 x 500 x 470 mm).
- Spare wheel on the front panel complete with lifting device.
- Side protections, lateral clearance lights.

OPTIONS

- Rear asphalt extension for finisher. (+ 43 kg.)
- Manual tarpaulin. (+ 200 kg.)
- Parking wedges with holders.