

**“SEMIROCCIA”**

Tail gate thickness	Front panel thickness	Body inside dimensions
5 mm	5 mm	5800 x 2300 x 1350 mm

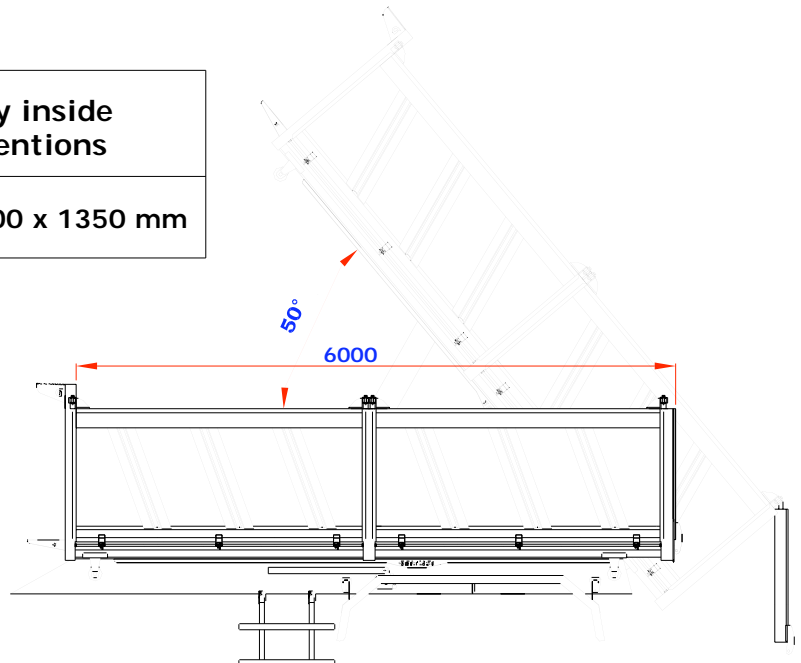
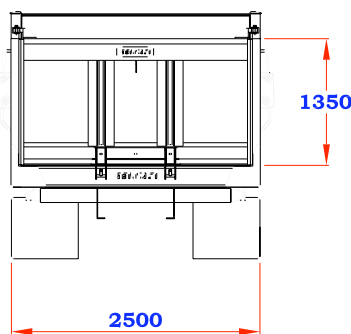

Body Volume	Tipping structure Weight	Floor	Side Walls	Body lifting angle
18 mc.	5400 kg.	HB 450 steel Thickness 8 mm	HB 450 steel Thickness 5 mm	Rear: 50° Lateral: 45°

The dimensions and weights are indicative. They can be changed without warning for manufacturing needs. F.lli Gervasi S.p.A.

**EMPLOY**

- Bulk material (sand, gravel, asphalt, .....).

**TIPPER BODY**

- Side walls with welded reinforcements.
- Front board with cab protecting lid.
- Side walls opening divided in two sections.
- Top hinged tail gate with automatic release.
- Tipping control by means of central telescopic hydraulic cylinder.
- Activation by means of pneumatic control from the cab.
- Painting:
  - Sandblasting by means of computerised system;
  - Application of polyurethane primer and finishing enamel.
- Painting colour: subframe in RAL 7021, body in customer colour.

**STANDARD EQUIPMENTS**

- Rear steel mudguards.
- Stainless steel tool box with lock ( 210 x 500 x 470 mm ).
- Spare wheel on the front panel complete with lifting device.
- Side protections, lateral clearance lights.

**OPTIONS**

- Manual tarpaulin. (+ 200 kg.)
- Rear asphalt extension for finisher. (+ 43 kg.)
- Parking wedges with holders.