

Tail gate thickness	Front panel thickness	Body inside dimensions
/	8 mm	5400 x 2300 x 1220 mm

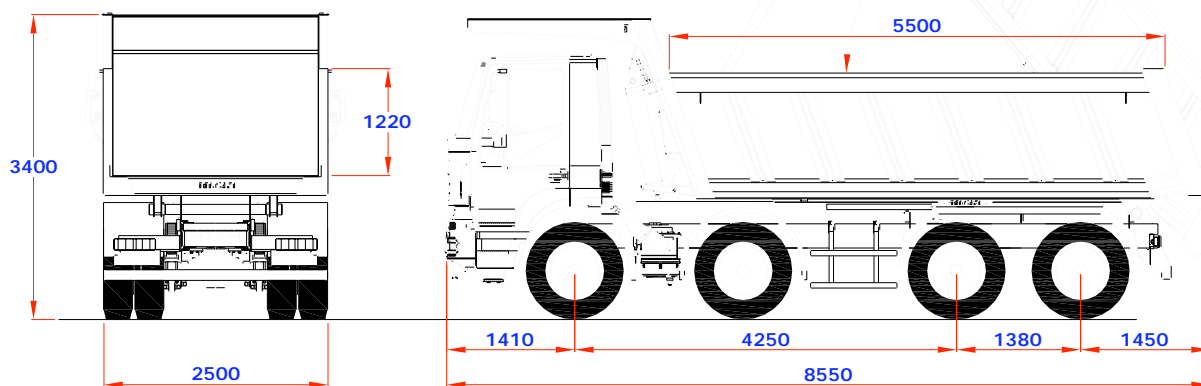

Body Volume	Tipping structure Weight	Total vehicle dead weight including tipping structure and spare wheel	Floor	Side Walls	Body lifting angle
15 mc.	5900 kg.	16500 kg.	HB 450 steel Thickness 12 mm	HB 450 steel Thickness 8 mm	50°

The dimensions and weights are indicative. They can be changed without warning for manufacturing needs. F.lli Gervasi S.p.A.

EMPLOY

- Transport of rocks.

TIPPER BODY

- Fixed side walls with welded reinforcements.
- Front board with cab protecting lid.
- Absence tail gate.
- Tipping control by means of front telescopic hydraulic cylinder.
- Activation by means of pneumatic control from the cab.
- Safety device at rear, bolted to the vehicle frame, complete with rubber body support when lifting.
- Painting:
 - Sandblasting by means of computerised system;
 - Application of polyurethane primer and finishing enamel.
- Painting colour: subframe in RAL 7021, body in customer colour.

STANDARD EQUIPMENTS

- Rear steel mudguards.
- Stainless steel tool box with lock (210 x 500 x 470 mm).
- Spare wheel on the front panel complete with lifting device.
- Cab overhead protecting lid.
- Side protections, lateral clearance lights.

OPTIONS

- Parking wedges with holders.